

**Boost your
business
with
perfect
milk foam.**



BlackStock[®]
COFFEE

Meet Lattiz.

The smart
milk solution
that makes
it easy to sell
more coffee
with optimal
hygiene.

BlackStock
COFFEE



ZERO
contact
for optimal hygiene

MACHINE  MILK FOAM  BARISTA



BlackStock
COFFEE

We like
coffee.

Milk
we love.

More than 40% of the coffees sold
are lattes and cappuccinos.
The great looks and taste are
all in the milk foam.

Perfect milk foam is crucial
to make your customers happy
and increase your sales and profit.

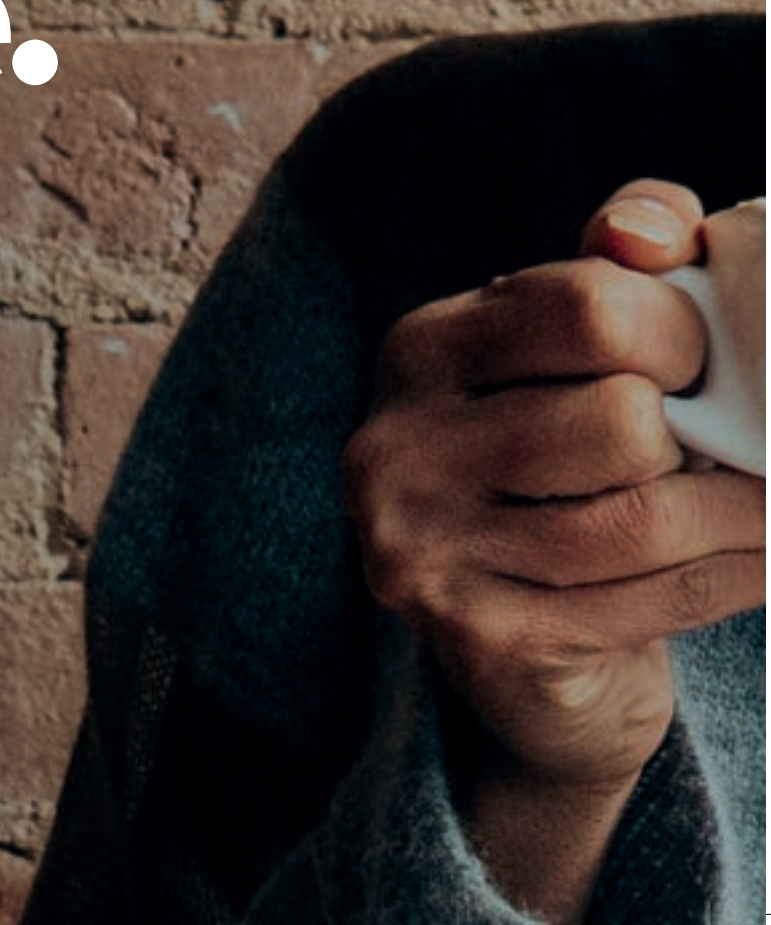



BlackStock
COFFEE

Lattiz helps you to serve perfect quality.

With perfect milk foam at the touch of a button

With constant high quality, cup after cup

With optimal hygiene, without contact between milk foam and the barista or machine

BlackStock
COFFEE

**Boost
your
business
with
perfect
milk foam.**



Serve quality

High quality milk foam,
cup after cup

Zero contact for
optimal hygiene

Perfect for latte art

Save time

One touch of a button

No waiting

No intensive cleaning
programs

Sell more

Happy customers come back

Serve more customers
at the same time

Increase coffee sales and profit



Perfect milk foam.

Optimal hygiene.

Lattiz is a unique, closed-system milk foam solution. Together with the innovative Lattiz pack, this ensures optimal hygiene.

- No contact between barista and milk foam.
- No contact between milk foam and machine.
- Always perfect milk foam that meets the highest hygienic standards.

Perfect and hygienic milk foam at the touch of a button, without intensive cleaning programs.



ZERO
contact
for optimal hygiene

MACHINE  MILK FOAM  BARISTA

Go for quality.

Being a good host comes with a challenge.
It requires skill, time and attention to offer
your customers a great coffee experience.

Due to changing personnel, consistency is
difficult to achieve and preparing coffee specials
and meeting high hygiene standards takes time.
Meanwhile, customers expect constant high quality
and they don't want to wait.

This is why Lattiz is here.

BlackStock
COFFEE



BlackStock[®]
COFFEE





One 4 liter Lattiz pack

Up to 140 cappuccinos*

Can stay inside the machine
for up to 10 days without cooling



Adapt to your needs

Choose your milk amount
and percentage of foam

Personalise your screen



No worries

No cleaning, no cooling
and no milk waste

Optimal hygiene

Less packaging waste

* Number of servings depends on cup size, product type and foam settings.

Boost your sustainable story.

 from cow

Sustainable Dairy Farming

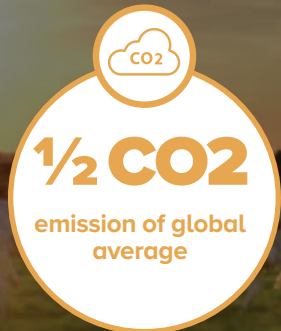

Research by Blonk Consultants, Oct. 2019

Sustainable Production & Packaging



Lattiz is sustainable from cow to cup. We strive to lead in sustainability throughout our whole supply chain. With Lattiz you choose for a sustainable way to boost your business.

..... to cup 

Sustainable Lattiz



20%*
lower
carbon footprint



35%
less
storage & handling



50%
less
packaging material



NO
fridges or cooling

** Between 19-23% compared to alternative foaming methods*



FrieslandCampina www.frieslandcampina.com

Lattiz and FrieslandCampina

Lattiz is part of Royal FrieslandCampina, one of the largest dairy companies in the world. With offices in 34 countries and exports to more than 100, FrieslandCampina serves millions of consumers every day.

FrieslandCampina is a cooperative, fully-owned by approximately 18.500 member dairy farmers spread across The Netherlands, Belgium and Germany. With almost 150 years of milk experience and control over the entire production chain, FrieslandCampina stands for the highest standards of quality, safety and sustainability, from grass to glass.

BlackStock
COFFEE



BlackStock
COFFEE



Lattiz pack

4 liters

Yield up to

140 cappuccinos or
75 latte macchiatos per pack *

Dimensions of closed machine

w x d x h 195 x 487 x 591

Dimensions of open machine

w x d x h 195 x 487 x 915

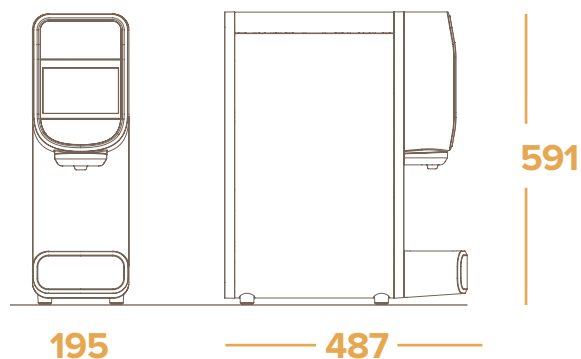

Power supply

230V / 50-60Hz / 3000W / 13A

Water supply

¾ BSP, installed within a regularly
maintained filter system

Required water pressure

1.5 - 6 bar

Weight

machine 13 kg

4G connection

This Lattiz machine is connected
with 4G

* Number of servings depends on cup size, product type and foam setting.
For example cappuccino using a 180 ml cup with 30 ml espresso and
barista-quality froth provides 140 servings and Latte macchiato using
a 300 ml glass with 30 ml espresso and barista-quality froth provides
75 servings.

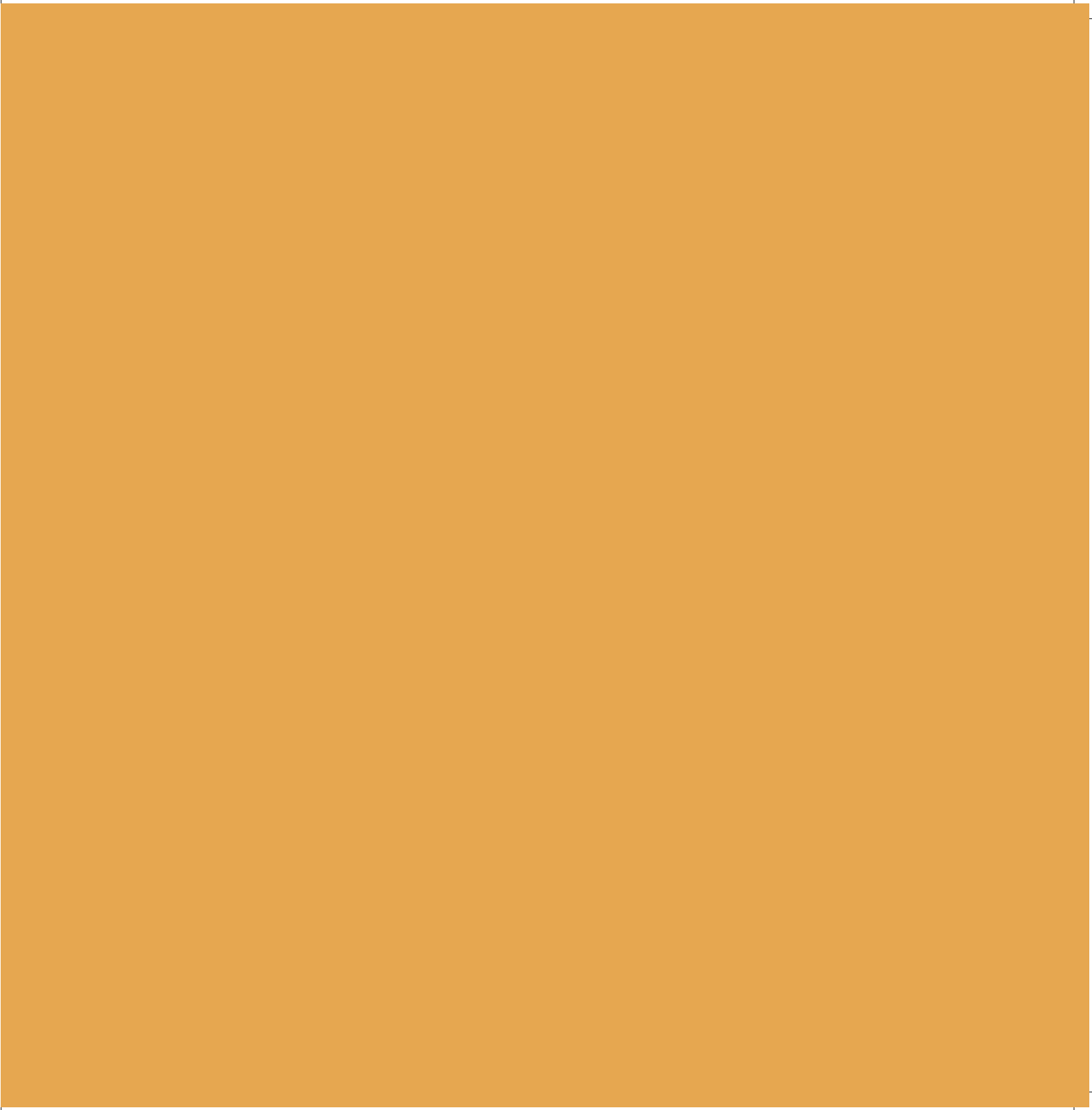

**See for yourself
at lattiz.com**